

G. T. SMITH.
JOURNAL BEARING.

No. 313,545.

Patented Mar. 10, 1885.

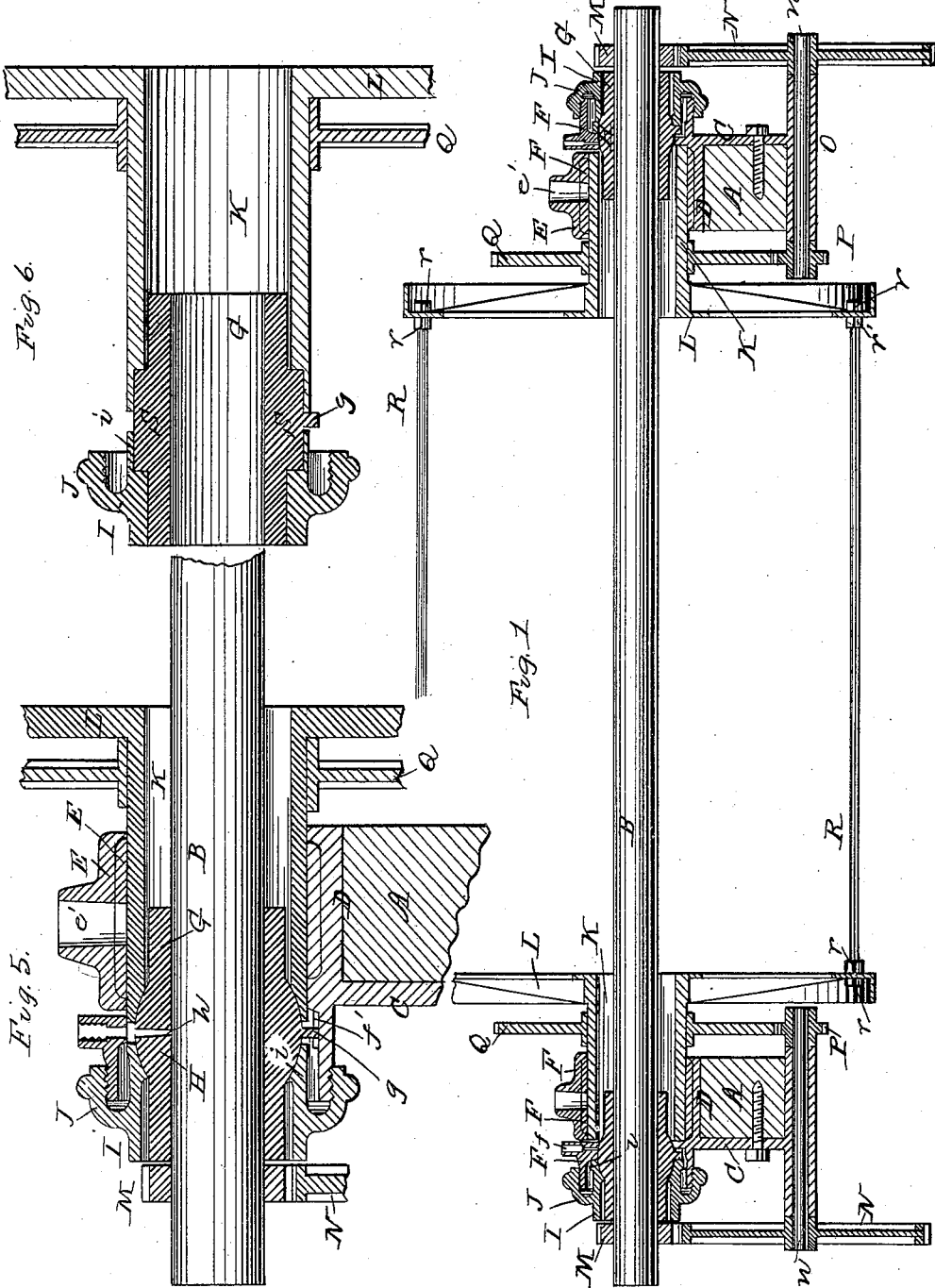

Witnesses
W. Burke
L. C. Marshall.

Inventor
George T. Smith
by Dumbleton & Bliss
attys.

G. T. SMITH.
JOURNAL BEARING.

No. 313,545.

Patented Mar. 10, 1885.

Fig. 2

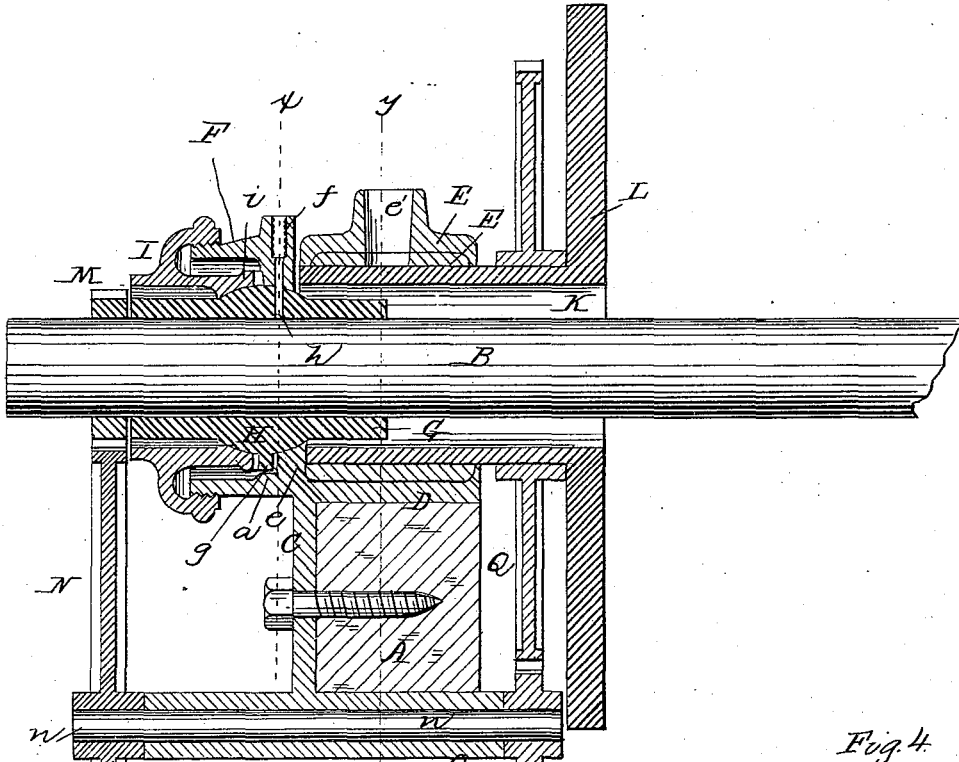

Fig. 3

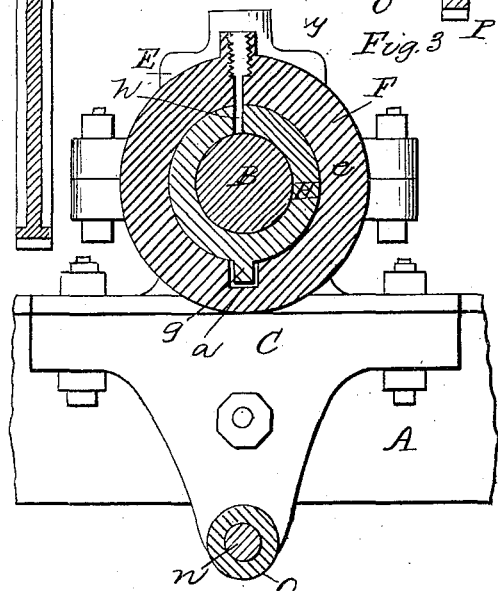
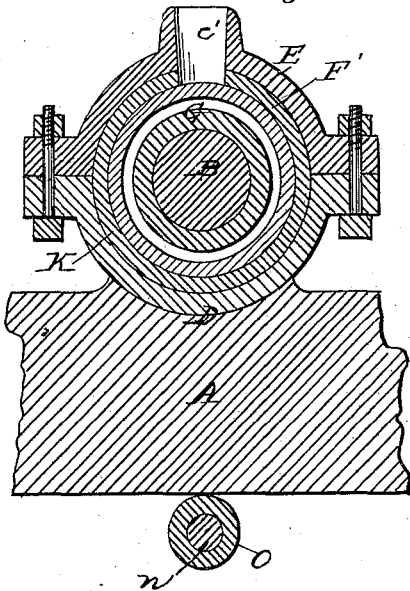

Fig. 4



With Trusses
H. B. Burke
L. B. Marshall

Inventor
George T. Smith
by Doubleday & Bliss
attys

UNITED STATES PATENT OFFICE.

GEORGE T. SMITH, OF JACKSON, MICHIGAN.

JOURNAL-BEARING.

SPECIFICATION forming part of Letters Patent No. 313,545, dated March 10, 1885.

Application filed July 24, 1884. (No model.)

To all whom it may concern:

Be it known that I, GEORGE T. SMITH, a citizen of the United States, residing at Jackson, in the county of Jackson and State of Michigan, have invented certain new and useful Improvements in Journal-Bearings, of which the following is a specification, reference being had therein to the accompanying drawings.

This invention relates to an improved journal-bearing, and has for its object the supporting of two concentric rotating devices or mechanisms by means of a compound bearing having a common cast-metal support, in such manner that the liability of undue strain or cramping of parts is greatly reduced, as will be hereinafter fully explained.

Figure 1 is a longitudinal section showing my invention as applied to a centrifugal reel. Fig. 2 is a view detached and enlarged of a portion of one end of the reel. Fig. 3 is a transverse section on line *x x*, Fig. 2. Fig. 4 is a transverse section on line *y y*, Fig. 2. Fig. 5 is a vertical longitudinal section showing a modification. Fig. 6 shows another modification.

In the drawings I have shown my invention in connection with so much of a centrifugal reel as is necessary to illustrate its construction and operation, and as the bearings may be used in duplicate at each end of the reel, I will confine my description to the right-hand one of Fig. 1, except so far as may be necessary in order to fully explain its operation.

A represents a cross-girt forming part of the frame-work, which may be of any usual or preferred construction, and need not be shown or described.

B is a beater-shaft, to which power may be applied through a belt-pulley or gear-wheel, and in practice carries a series of spiders and beaters, which are not shown.

C D E F represent a supporting boxing or casing, of cast metal, of which the part C is a flat vertical web or flange bolted to the face of the girt A.

D E is a circular shell, which may be either cast in one piece or, by preference, the part E is made in the form of a cap having laterally-projecting ears or flanges adapted to be bolted to corresponding ears which project

from the lower half, D, as shown in Figs. 2 and 3.

F is a cylindrical shell projecting laterally and outwardly from the part C D.

e is a flange projecting inwardly from the cylindrical part F and forming a shoulder-bearing, which in this instance is concave in transverse section to fit a convex surface to be described.

G H is a sleeve fitting closely the shaft B, and expanded at H, so as to form an enlargement or bearing adapted to fit the inner face of the inwardly-projecting shoulder-bearing *e*.

I J is a follower, the flange portion J having an interior thread adapted to engage with the outer end of the part F, which is correspondingly threaded, the inner part or portion, *i*, being concave, so as to engage with the part-spherical bearing H of the sleeve and hold it firmly in contact with the inner edge of the shoulder-bearings *e*. Thus it will be seen that this sleeve G H is held firmly between two separable members of a bearing which is divided on a vertical plane, the detachable member being adjustably connected with the cylindrical shell F.

f is an internally-threaded socket adapted to receive the neck of an oil-cup, there being a gland or oil-hole, *h*, formed in the upper surface of the sleeve to conduct oil to the interior of the sleeve.

To prevent the sleeve from rotating with the shaft B to such an extent as to interfere with the registering of these oil-holes, while permitting sufficient movement of the sleeve in other directions, I provide it with a projecting lug, *g*, which enters a recess, *a*, in the interior of the shell or cylindrical part F, this recess being by preference formed in the shoulder-bearing *e*.

As will be readily understood by an examination of Figs. 1 and 2, the follower forces the sleeve-bearing against the shoulder-bearing *e* so closely that the lug cannot escape from the recess.

K L represent, respectively, the hollow trunnion and head of the reel at each end of the flour-bolt, the reel-heads being connected by longitudinal bars R R, which pass through the heads near their peripheries, and are provided at each end with two nuts, *r r*. The trunnion

K is also supported by the casting or boxing C D E F, and, by preference, I babbitt this bearing, as indicated at E', and there should be an oil hole or receptacle, *e'*, in the upper cap portion, E'. I do not wish, however, to limit myself to making the cylindrical part or shell D E in two sections. The outer end of the trunnion may abut against the shoulder-bearing *e*, and as the distance between the heads at the opposite ends of the reel may be adjusted by means of the nuts *r r* on longitudinal bars R R, the outer ends of these trunnions may be made to engage with the flanges *e e*, and longitudinal movement of the reel thereby prevented.

M is a spur-pinion keyed to shaft B, and meshing with a spur-gear, N, keyed to shaft *n*, which is supported in a sleeve-bearing, O, cast in one and the same piece with the casing or boxing which has just been described.

P is a pinion on the inner end of shaft *n*, meshing with the spur-gear Q, mounted upon and keyed to the hollow trunnion K.

By means of the pinion M and a corresponding pinion or collar at the opposite end of the machine longitudinal movement of the beater-shaft may be prevented, and in case great accuracy of adjustment and fit of parts is desired the position of the spur-pinion or the collar or both upon the shaft may be adjusted to correspond with the position of the follower when the parts are put together, or whenever any subsequent adjustment of these followers be made to correspond with the wear of the sleeve-bearings or other parts of the mechanism.

I have shown in the drawings no provision for introducing material to the interior of the reel, which may be fed either between the spokes of the reel-head or by any other feeder which is adapted to deliver meal through an opening which is eccentric to the beater-shaft.

The driving-pulley may be attached to the beater-shaft at either end of the machine, as shall be thought best, and its hub may be made to serve as a stop in place of the spur-pinion M, or of a collar at the opposite end of the bolt.

In the modification shown in Fig. 5 substantially the same construction of boxing or casting C D E F is shown, except that the shoulder-bearing, instead of being formed in a flange projecting inwardly from the boxing, is in this instance formed upon the inner surface of the hollow trunnion K, the parti-spherical enlargement or bearing of the sleeve being confined between this shoulder-bearing in the trunnion and the follower, substantially as is done in the construction shown in Figs. 1, 2, 3, 4. In this modification, however, I propose to form the cylindrical shell F with two inwardly and upwardly projecting ribs, *o*, between which the lug enters, and by means of which the sleeve is prevented from rotating with the shaft.

From the above description it will be understood that, power being applied to shaft B, so as to rotate it, the reel will be driven at

comparatively slow speed, and it will be seen that both the shaft and hollow trunnion have long bearing-surfaces by reason of one end of the sleeve projecting about half-way through that portion of the trunnion which is seated in its surrounding shell D E of the boxing. It will also be understood that by reason of the concentric arrangement of these bearings, and of their being supported upon the boxing, which is cast in one and the same piece of metal, there is very little possibility of any undue cramping of parts resulting from the warping or settling of any part of the machine or of the floor or other foundation upon which it is mounted, it being apparent that if from any cause one end of the reel should settle a little, or the shaft should be sprung, or from other cause deflected, the parti-spherical bearing will adjust itself so that the parts can run without material increase of friction.

In the modification shown in Fig. 6 the outer bearing of the sleeve G S is cylindrical in form and of substantially the same diameter at both ends, with the bearing-surfaces at its ends formed in planes at right angles to the axis of the shaft B, and does not, therefore, possess all the advantages of function and mode of operation which are incident to the sleeve-bearing shown in the other figures, the modifications in the forms of the shoulder-bearing and of the inner end of the follower being such as to adapt them to properly engage with the flat ends of the bearing S, although this construction has many features in common with that shown in the other figures.

By means of the adjustable followers, and of the nuts on the longitudinal bars R R, such adjustments of the various parts may be made as shall insure close-fitting and smoothly-running joints, together with compensation for wear, whereby undue end play or movements of the reel, the beater-shaft, or the bearings relative to either of the others may be obviated.

While I have shown one of these bearings at each end of a centrifugal reel, it is apparent that it is adapted for use upon very many well-known machines, in which a face-plate or gear-wheel is mounted to rotate about an interior spindle—such as a lathe or a boring-machine, for example, in which, ordinarily, the face-plate or flange and the interior spindle are connected together by a train of gearing substantially like that shown at M N P Q. Therefore I do not wish to be limited to its use in connection with any particular class of machines or devices.

While I prefer to make the enlarged or semi-spherical portion H or S of the sleeve of about the diameter shown relative to the diameter of the hollow trunnion, and the part G of the sleeve of such diameter as to fit loosely within the hollow trunnion, yet I do not wish to be limited to the proportions shown; and some of the advantages incident to my invention might be attained without making the

inner end of the sleeve of such diameter that it will enter the hollow trunnion, in which case the inwardly-projecting flange *e* might be extended much nearer to the shaft B than is shown; nor do I wish to be limited to the exact construction of follower shown, because it might be made in the form usually adopted for the gland of a stuffing-box, the shell F having projecting ears with bolts or set-screws, by which the gland can be forced inward against the bearing G or S, because I believe myself to be the first to support a sleeve of the character shown in a two-part bearing divided upon a vertical plane.

15 In the construction shown in Fig. 5 the oil-hole *h* in the sleeve G H might be made a good deal larger than the one in the bearing of the socket *f*, to insure that the lubricant shall be properly directed to the shaft within the sleeve. 20 If the lug *g* and its corresponding socket be omitted, I should prefer to construct the sleeve with a number of oil-holes arranged in the semi-spherical plane around its circumference to facilitate the introduction of oil to the shaft.

25 What I claim is—

1. In a journal-bearing, the combination, with the shaft and the sleeve provided with an expanded bearing, of a boxing having an adjustable two-part bearing divided upon a vertical plane, substantially as set forth.

2. In a journal-bearing, the combination, with a shaft, of the sleeve having an expanded external bearing, a boxing or casing provided with a shoulder-bearing, and the follower adapted to support the sleeve, substantially as set forth.

3. In a journal-bearing, the combination of

the shaft, the sleeve provided with an expanded bearing, the trunnion, and the casing having a shell adapted to support the trunnion, and also the divided bearing for the sleeve, substantially as set forth.

4. In a journal-bearing, the combination of the shaft, the sleeve, the boxing or casing adapted to receive the trunnion and support the end of the trunnion against thrust, and a two-part bearing for the sleeve divided upon a vertical plane, substantially as set forth.

5. In a journal-bearing, the combination of the shaft, the sleeve, the boxing or casing adapted to receive the trunnion and support the end of the trunnion against thrust, and provided, also, with the externally-threaded shell, and the follower adapted to engage with the threaded shell, and also with the bearing of the sleeve, substantially as set forth.

6. The combination, with the shaft, of the sleeves, the two boxings, and the trunnions supported in the boxings and connected with each other, whereby the boxings are adapted to prevent longitudinal movement of the trunnions relative to the shaft, substantially as set forth.

7. The combination of the shaft, the sleeves, the boxings, the trunnions, and means, substantially as described, for adjusting the trunnions longitudinally upon the shaft, substantially as set forth.

In testimony whereof I affix my signature in presence of two witnesses.

GEORGE T. SMITH.

Witnesses:

FRED. W. SMITH,
GEO. S. BENNETT.